

# GUARDIAN ALERT

*Enjoy the Freedom of Independent Living*

## OPERATING INSTRUCTIONS Model No. 30911

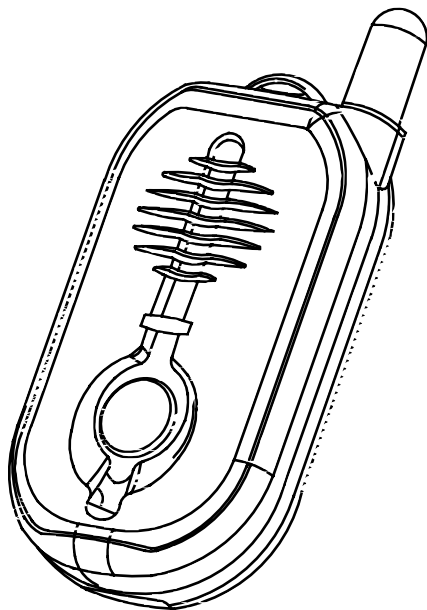

Note: Battery must be installed before use.

Thank you for choosing the Guardian Alert – your personal link to the 000 emergency operator when you need it.

**PLEASE READ THIS MANUAL COMPLETELY AND SAVE IT FOR REFERENCE.**

**Contents:**

The items below are included with your Guardian Alert. Additional parts or replacements can be ordered from Damaco Pty Ltd by calling our Customer Service department at 1300 78 03 07.

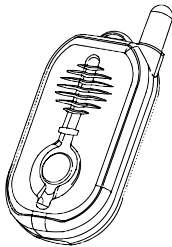

**Pendant**

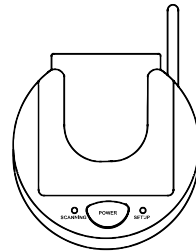

**Base Unit**

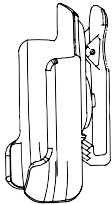

**Belt Clip**

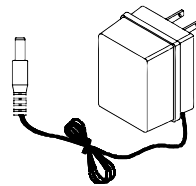

**AC Adapter**

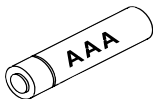

**AAA Alkaline Battery**



**Phone Cord**



**Screwdriver**

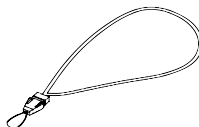

**Lanyard**

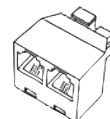

**Line Splitter**

## Optional Accessories:



**Battery Backup #30912**

## TABLE OF CONTENTS

<b>Overview of the Guardian Alert .....</b>	<b>4</b>
<b>Installing the Battery .....</b>	<b>4</b>
<b>Locating the Base Unit.....</b>	<b>5</b>
<b>Pendant Features .....</b>	<b>5</b>
<b>Base Unit Features .....</b>	<b>6</b>
<b>Connecting the Guardian Alert</b>	
The Standard Connection.....	6
Connecting a Second Phone.....	7
If Your Home Has DSL.....	7
<b>Operating the Guardian Alert</b>	
About the Pendant.....	7
Attaching the Lanyard.....	8
Water Resistance.....	8
Battery Check.....	9
System Check.....	10
Emergency Dialing Using the Panic Button .....	11
Hanging Up.....	11
<b>Troubleshooting Guide .....</b>	<b>12</b>

## Overview Of The Guardian Alert:

The Guardian Alert is a tiny cordless speaker phone, small enough to be worn around your neck. It is smaller than most cell phones.

By pressing a single button, the Guardian Alert automatically dials the universal 000 emergency number. You will then be able to speak directly to the 000 operator about your emergency.

It has enough range to cover most homes and even into the yard. It is NOT a cell phone, and therefore will not work far from your home. It is designed to be used primarily inside the home. You can use the System Check feature (see page 10) to confirm that the PENDANT is within range of the BASE UNIT.

The Guardian Alert PENDANT has its own replaceable battery. The battery must be installed prior to use. It will last at least 6 to 12 months in standby mode. Because the PENDANT never needs charging, it can be kept with you at all times. We recommend that the PENDANT battery be replaced every six months.

Like most cordless phones, the Guardian Alert must be plugged into a power outlet using an AC adapter (included) to work. An optional battery backup is available which can keep the Guardian Alert BASE UNIT working for up to 24 hours in case of a power failure. It can be ordered from the Customer Service number on the back of this manual. Ask for part number 30912.

### Installing the Battery:

It is important to know that the PENDANT requires one AAA battery. We recommend using a fresh, high quality alkaline or lithium cell from a recognized brand. Under normal use, the unit will remain on standby and ready for use for at least six months. When activated during an emergency, you can talk for a minimum of 30 minutes. Follow the diagram to the right to install the battery which came with your kit.

To insure that your Guardian Alert will be ready when you need it, replace the battery every 6 months.

**NOTE:** *The battery cover will only fit easily on the case one direction.*

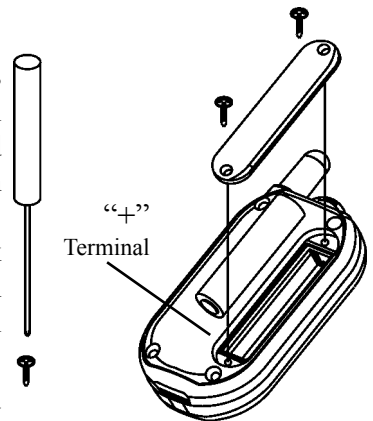

## Locating the Base Unit:

For best results and longest range, locate the BASE UNIT in an area away from household appliances which could present electrical interference. These include microwave ovens, televisions, electric mixers or blenders, hairdryers, or other cordless phones.

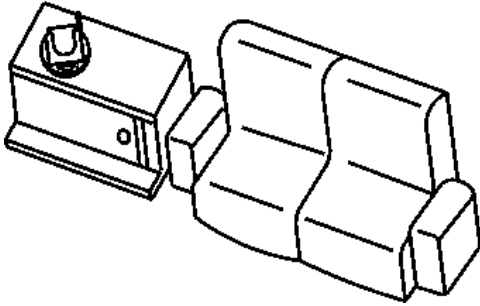

**Good Location**

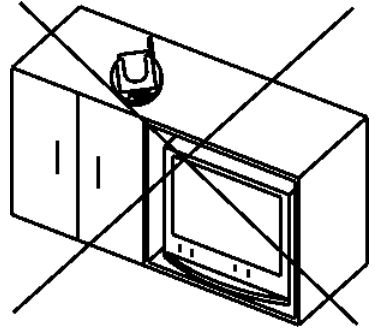

**Bad Location**

If more than one Guardian Alert is to be used in one home, it is recommended that the BASE UNITS be located at least 10' (3 meters) apart. Do not install more than two Guardian Alert in one home. When 1 phone is used, it should be located near the center of the home.

## Pendant Features:

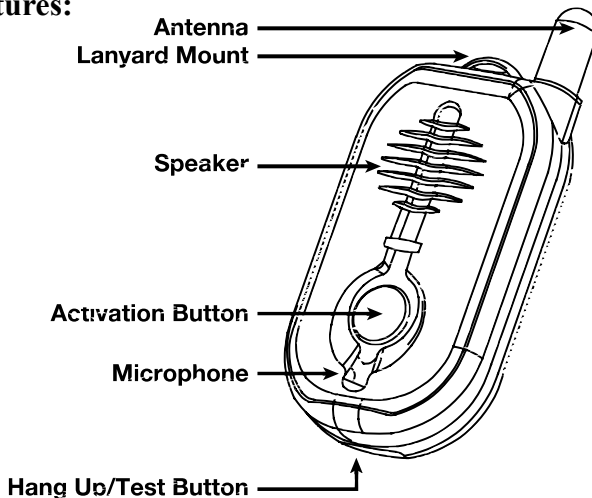

## Base Unit Features:

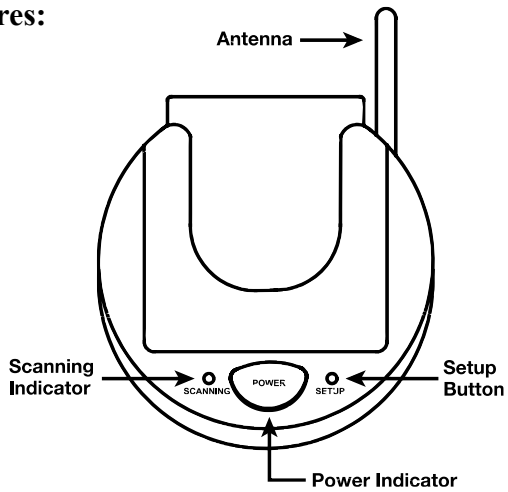

## Connecting The Guardian Alert:

### The Standard Connection:

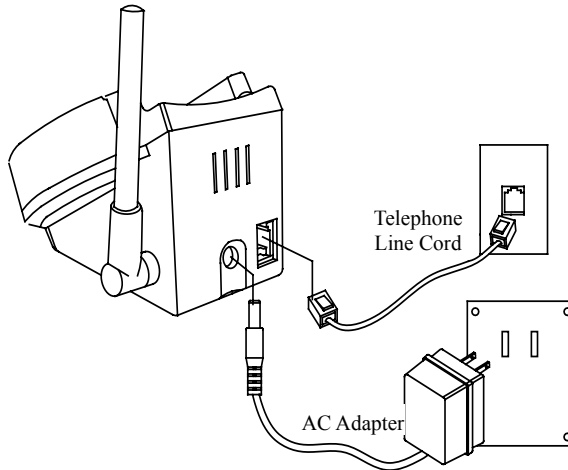

No special phone line or special service is required to use your Guardian Alert. Your phone will work with your existing touch-tone phone line and existing service. It works the same way as any cordless phone.

Simply plug in the AC ADAPTER and TELEPHONE LINE CORD as shown.

---

**Ensure the A/C adaptor is plugged into a switch that operates.**

---

### **Connecting A Second Phone**

You may need to plug a conventional telephone into same outlet used by the Guardian Alert. This is done very simply by using the telephone line splitter (included). See illustration on right.

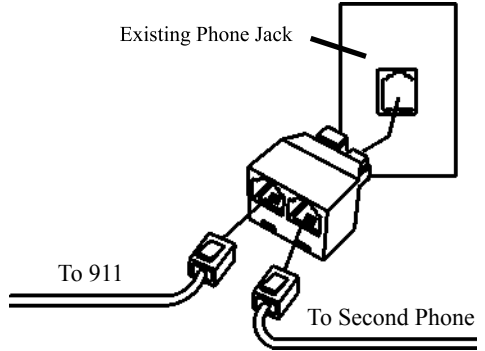

### **If Your Home Has DSL**

If your home has DSL service for your computer, you will need to use a DSL filter in line with the Guardian Alert **OR IT WILL NOT WORK**. This filter can be obtained from a local electronics supplier or your DSL service provider. See illustration to the right.

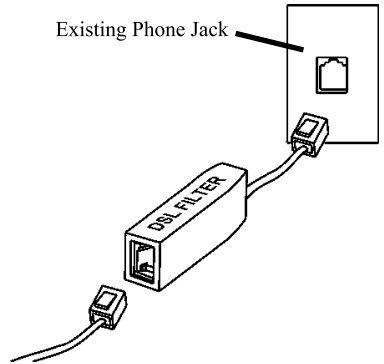

## **Operating the Guardian Alert**

### **About The Pendant:**

The PENDANT is a tiny, cordless speaker phone. It may be worn around the neck, on a belt using the supplied clip, or kept in your pocket.

There is a large blue button on the front of the PENDANT which activates the system and automatically dials the 000 emergency number when pressed for more than ½ second.

Once connected, you can speak directly with the 000 operator and explain the nature of your emergency.

## Attaching The Lanyard

If the neck strap is to be used, attach it as shown to the right.

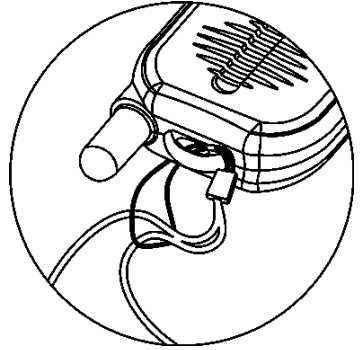

## Water Resistance

The Guardian Alert will resist occasional splashes from water. However, it should never be submerged or exposed to water continuously.

## Battery Check

The Guardian Alert has a built-in battery tester. When you press the button on the bottom of the PENDANT, a voice announcement will inform you of the battery condition. One of the following messages will be heard:

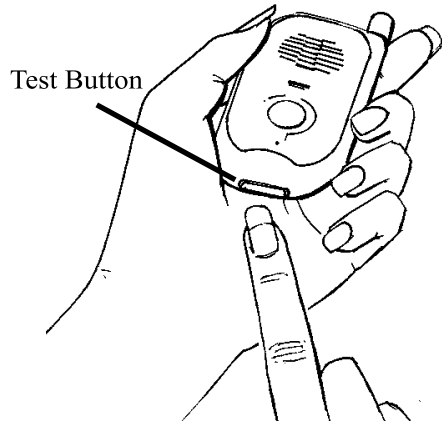

### **“Battery is OK.”**

Check the battery condition once per week.

### **“Replace battery soon.”**

The battery should be replaced within the next few days.

### **“Replace battery now.”**

The battery should be replaced the same day.

Please note: If there is no response after pressing the button for one second or more, the battery is dead and must be replaced immediately.

---

The battery should be tested twice a month along with the System Check outlined on the next page. If the battery is tested every day, it will be drained much more quickly and will not last as long.

---

## System Check

The button on the bottom of the case which is used to perform the BATTERY CHECK, will also perform a SYSTEM CHECK. Press and hold this button for more than four (4) seconds. One of the following announcements will be made.

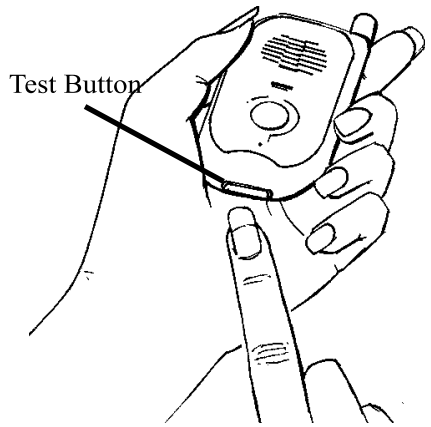

### “System check, OK.”

This confirms the following:

Battery status.

The PENDANT is working.

The BASE UNIT is working.

The BASE UNIT is connected to a working phone line.

The PENDANT is within range of the BASE UNIT.

### “System check failed.”

This confirms one or more of the following:

The PENDANT has malfunctioned.

The BASE UNIT has malfunctioned.

The PENDANT and BASE UNIT are not communicating with each other or are out of range.

The BASE UNIT is not connected to the phone line or can not get a dial tone for some reason.

If you receive a “System check failed.” notification, please refer to the TROUBLESHOOTING guide at the back of this manual to determine the cause.

**This feature is very useful - allowing you to confirm that the system has coverage from all parts of your home. Simply walk to the various parts of your home and push the Battery Check / System Check button until you hear the dial tone and the “SYSTEM CHECK OK” voice prompt.**

**We highly recommend that you perform this test every 2 to 4 weeks to confirm that your system is working properly and that the pendant and base station are in good communication and that the base station can get a dial tone. It is also recommended to perform this system check after a lightening storm that could damage the base station which is plugged into the phone line.**

## **Emergency Dialing Using the Panic Button**

In the event of an emergency, press the blue panic button on the front of the PENDANT. When this button is pressed for more than ½ second, the Guardian Alert will automatically dial 000. When the emergency response operator answers, speak in a normal voice and you will be heard. There is no need to put the PENDANT up to your ear unless you are having trouble hearing. There is no need to hold the PENDANT up to your mouth. You will be clearly heard, even if the PENDANT is an arm's length away.



## **Hanging Up**

You can hang up any time by pressing the TEST BUTTON on the bottom of the case.

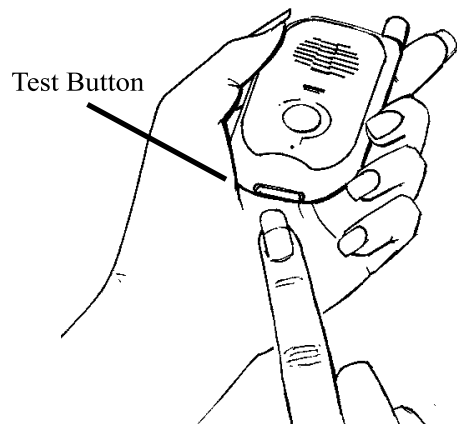

# TROUBLESHOOTING GUIDE

## What if I can't get the Guardian Alert to work?

### Step 1 – Check the PENDANT.

What to do:

Press the BATTERY CHECK/SYSTEM CHECK button on the bottom of the PENDANT.

What to expect:

The a voice should announce the condition of the battery.

A light on the front of the PENDANT will come on.

If nothing happens, the most likely cause is that the battery is dead or has been installed backwards.

If the PENDANT seems to be working, go on to step 2.

### Step 2 – Check the connections on the BASE UNIT

What to do:

Make sure the AC ADAPTER is plugged into a live AC outlet and into the BASE UNIT.

What to expect:

The blue POWER light will be on if the BASE UNIT is connected to power.

If the POWER light is on and the BASE UNIT is connected to a working phone line, go on to step 3.

### Step 3 – Make sure the PENDANT and the BASE UNIT are talking to each other.

Background information: The PENDANT and the BASE UNIT are connected by a wireless radio link. They must be synchronized to work together. They should have already been synchronized at the factory, but resetting this is simple.

What to do:

1. Press the “SET” button on the BASE UNIT until the red “SETUP” light comes on. Release the SET button.
2. Now press and hold the PANIC BUTTON and the TEST BUTTON buttons together until the “setup” light on the BASE UNIT turns off.

What to expect:

The red light will go out on the BASE UNIT. This indicates the PENDANT and the BASE UNIT are synchronized. At this point, everything should be working fine.

**If your Guardian Alert is still not working, call our TECH SUPPORT department at 1300 78 03 07.**

Information The ACMA Wants You To Know:

FCC ID: TYD30911

This unit complies with all the relevant Telecom (Australia and New Zealand) applicable compliance.

### **Operating Range:**

The operating range of your Guardian Alert will depend on many factors including intervening walls, electrical interference or various appliances such as vacuum cleaners, microwave ovens, mixers, coffee grinders, hair dryers and other sources of electrical noise around the house.

# General Warnings And Precautions!

## Warning!

- Damaco Pty Ltd DOES NOT represent this unit to be completely waterproof. To reduce the risk of damage to the unit, DO NOT expose the pendant or base unit to prolonged water, rain or moisture.
- The Guardian Alert is intended for residential use only. It may not work properly if connected to some commercial phone systems.
- The Guardian Alert works with tone dialing systems only. Do not use if you have pulse dialing only.
- This product and/or accessories may contain lead, a chemical known to cause birth defects or other reproductive harm.

## Disclaimer:

Damaco Pty Ltd will not be responsible for the improper use of the Guardian Alert, nor will it be responsible for failure resulting from the use of other equipment connected to the same phone line. We will not be responsible for the quality of the phone line or the reliability or quality of the phone service with which the Guardian Alert is used.

Damaco Pty Ltd will not be responsible for the installation of the Guardian Alert. It will not be responsible for the improper use or abuse of this unit.

## Important Safety Instructions:

**When using your Guardian Alert, please observe the following instructions in order to reduce the risk of personal injury, electrical shock, or fire.**

1. Save these instructions for future reference.
2. Read all instructions carefully and make sure you understand them.
3. Unplug this product from the electrical outlet before attempting to clean it. Do not use any liquids for cleaning either the Base Unit or the Pendant. Use only a soft damp cloth.
4. Do not locate the Base Unit near any source of water, such as in the bathroom, near a sink in the kitchen, or the like.
5. Do not open the unit, (except the battery compartment as directed in these instructions) on the Pendant for any reason. Any attempt to open the case of the Base Unit or the Pendant will void the warranty and may damage the unit or prevent it from working properly.

6. Do not use any power source other than that supplied from Damaco Pty Ltd specifically for this product. Use of any other power source could damage your unit or make it unsafe.
7. If your unit becomes damaged do not attempt to repair it. Please return it to Damaco Pty Ltd for service or replacement as stipulated below under “ONE YEAR LIMITED WARRANTY”.

---

### **ONE YEAR LIMITED WARRANTY**

Damaco Pty Ltd warrants to the original consumer/purchaser that this product shall be free of defects in material and workmanship under normal use and circumstances for a period of **one** (1) year from the date of original purchase for use. When the original consumer/purchaser returns the product pre-paid to within the warranty period, and if the product is defective, Damaco Pty Ltd will at its option repair or replace such.

This warranty shall constitute the sole liability of Damaco Pty Ltd concerning the product. Damaco Pty Ltd expressly disclaims all other warranties INCLUDING, WITHOUT LIMITATION, THE WARRANTIES OF MERCHANT ABILITY AND FITNESS FOR A PARTICULAR PURPOSE. NO PERSON, FIRM, OR CORPORATION IS AUTHORIZED TO ASSUME FOR Damaco Pty Ltd. ANY OTHER LIABILITY IN CONNECTION WITH THE SALE AND USE OF THE PRODUCT. Damaco Pty Ltd and agents and distributors will bear no liability whatsoever for incidental or consequential damages or charges of any kind.

Some states do not allow the exclusion or limitation of incidental or consequential damages, so the above disclaimer regarding incidental or consequential damages may not apply to you.

This warranty is void if the product has been damaged or tampered with or if the product or any such parts have been opened. In all cases of damage during shipment, a claim must be filed with the shipping carrier and not with Damaco Pty Ltd.

This warranty gives you specific legal rights; you may also have other rights which vary from state to state.

### **OUT OF WARRANTY REPAIRS**

If the warranty period has expired or if you are not the original owner of the product, Damaco Pty Ltd will at its option either (1) replace this product with a functionally similar (but not necessarily identical) refurbished product or (2) repair the original product and return it to the original consumer/purchaser after payment of repair/replacement charges has been received.

***DAMACO***

Locked Bag 1002  
Hamilton, Victoria, Australia 3300

Tel: 1300 780 307

**[www.Damaco.com.au](http://www.Damaco.com.au)**